

PRODUCT DATA SHEET

TROWELABLE COVING RESIN

PRODUCT DESCRIPTION

Stonshield Coving Resin 980 is a 2-component epoxy paste used in conjunction with Stonshield 981 Aggregate. It is formulated to improve the trowelability of the Stonshield Decorative Aggregate systems on vertical and horizontal surfaces.

TYPICAL USES

Placement of cove skirting between floor and wall typically at 25 to 50mm radius away from the corner of the wall. Product can also be plastered on vertical surfaces and staircases to create a seamless, non-porous joint-free smooth decorative tweed finish. Ideally suited for use in health care, educational, pharmaceutical, food and beverage facilities where ease of cleanability, non-destructive surfaces are required.

PRODUCT ADVANTAGES

- 100% Solids, low VOC.
- Long term abrasion and chemical resistance.
- Provides an integral seal at junction of Stonhard floor system and wall finish.
- Protects against moisture penetration.
- Durable gloss finish permits easy cleaning and maintenance.

NOTE: Staining may occur depending on length of exposure time, chemical concentration and temperature.

PACKAGING AND COVERAGE

Stonshield 980 Coving Resin A & B = 2,5L kit of resin

Stonshield 981C Coloured Aggregate = 5L (8kg) measured with a 5L bucket on site. Aggregate supplied in 25kg bags. Yield 6 litres

Coverage: 10 linear metres for a 50mm x 100mm x 3mm cove skirting formed with a 25mm radius coving trowel.

REFERENCE SAMPLE

A trial reference sample should be installed by the applicator prior to start of contract to ensure correct coverage and workmanship.

TYPICAL PROPERTIES AT 25°C

Pot Life	20 to 30 Minutes
Finish	Smooth gloss
Volume Solids	100%
Cure Rate	4 Hours for tack-free 16 Hours light traffic 7 Days full cure
Temperature Limitations	60°C
Application Temperature	15°C to 35°C
VOC Content	14g/litre
Apply By	Coving trowel

NOTE: The above physical properties were measured in accordance with the referenced standards. Samples of the actual floor system, including binder and filler, were used as test specimens. All sample preparation and testing is conducted in a laboratory environment, values obtained on field applied materials may vary and certain test methods can only be conducted on lab made test coupons.

APPLICATION SPECIFICATION FOR STONSHIELD COVING

SUBSTRATE PREPARATION

Stonshield Coving 980 Resin is suitable for application over properly prepared concrete surfaces that do not require renovation. The substrate must be dry and free of all wax, grease, oils, fats, soil, loose or foreign materials and laitance. Laitance and unbonded cement particles must be removed by mechanical methods, i.e. abrasive blasting or scarifying. Other contaminants may be removed by scrubbing with Carboclean 250 and Carboclean 252 and rinsing with clean potable water. The surface must show open pores throughout with main aggregate in concrete exposed, and have a sandpaper texture. Substrate moisture content prior to coating should be below 5% and substrate tensile strength above 2 MPa. For recommendations of additional information regarding substrate preparation, please refer to surface preparation data sheet or contact StonCor Africa Technical Service Department.

MIXING

Empty the entire contents of the Stonshield 980 A & B components into a clean, dry 10 litre mixing container. Mix thoroughly for 2 minutes with an impeller fitted to a variable speed drill, then add a full 5 litre bucket measure of Stonshield 981C Coloured Aggregate and mix for a further 2 minutes. This step is critical to ensure complete wetting of components is achieved. **Do not aerate mix nor mix by hand.**

APPLICATION

1. Install a metal coving strip to the wall at the desired height using a silicone bead, taking care to mask above the cove strip for neatness. Place a 3 – 4mm screeding bar on the floor at the specified distance from the wall to act as a straight edge.
2. Prime the wall and floor area with Stonshield 980 A & B resin only, at 3 to 4m²/litre.
3. Into the wet primer, apply the Stonshield A, B & C mixed mortar using a flat steel trowel, packing material into the corners. Coloured aggregate rubbing blocks can also be made with the same mortar for removing imperfections, when cured.
4. Using the desired radius coving trowel (normally 25mm), shape the mortar running the trowel along the metal strip on the wall and the straight edge on the floor, shaping the cove. Ensure all trowel marks are removed and the surface is smooth.

5. If material becomes tacky on the trowel, wipe it clean using epoxy thinners, and smooth the area again.
6. Allow to cure overnight before abrading the imperfections with the coloured aggregate rubbing blocks.
7. Seal the surface with Stonseal 787 or the specified sealer.

Please refer to SLT-SA Directions for further detail.

RECOMMENDATIONS

- DO NOT attempt to install material if temperature of Stonshield components and substrate are not within 15-35°C. The cure time and application properties of the material are severely affected.
- DO NOT use water or steam in the vicinity of the application. Moisture can seriously affect the working time and other properties.
- Protect areas from dust and isolate access. Contamination between layers will affect the final appearance.
- Avoid contact with all liquid Parts A and B as they may cause skin and/or eye irritation. Workmen should cover hands with protective creams or rubber gloves and wear safety glasses.
- Use only with adequate ventilation.

NOTES

- Procedures for maintenance of the flooring system during operations are described in “StonCor Cleaning Procedures”.
- Specific information regarding chemical resistance is available in the Chemical Resistance Guide”.
- Material Safety Data Sheets are available on request.
- A staff of technical service engineers is available to assist in installation or to answer questions related to our flooring products specifically or flooring problems in general.
- Requests for technical service or literature can be made through local sales representatives and offices, or corporate offices located throughout the world.

CAUTION: MAY CONTAIN FLAMMABLE SOLVENTS. KEEP AWAY FROM SPARKS AND OPEN FLAMES. IN CONFINED AREAS WORKMEN MUST WEAR FRESH AIRLINE RESPIRATORS. HYPERSENSITIVE PERSONS SHOULD WEAR GLOVES OR USE PROTECTIVE CREAM. ALL ELECTRONIC EQUIPMENT AND INSTALLATIONS SHOULD BE MADE AND GROUNDED IN ACCORDANCE WITH THE NATIONAL ELECTRICAL CODE. IN AREAS WHERE EXPLOSION HAZARDS EXIST, WORKMEN SHOULD BE REQUIRED TO USE NONFERROUS TOOLS AND TO WEAR CONDUCTIVE AND NONSPARKING SHOES



StonCor Africa (Pty) Ltd

Co. Reg. No. 1996/001848/07

Tel: +27 (0)11 254 5500

Website: www.stoncor.co.za

E-mail: stoncorsa@stoncor.com

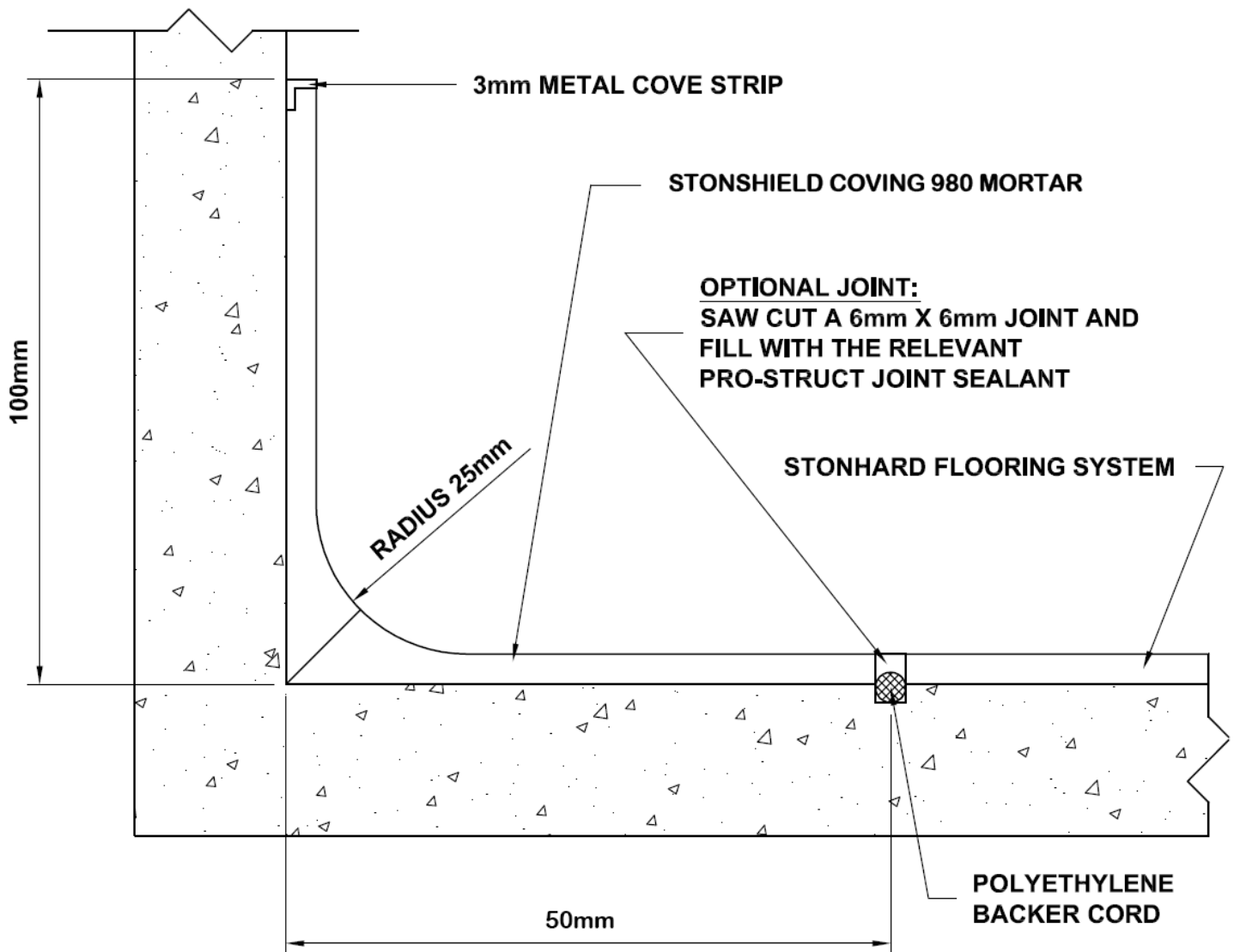

APPLICATION PROCEDURE FOR EPOXY MORTAR COVERED SKIRTINGS

- ▶ Epoxy mortar covered skirtings shall be installed prior to the installation of the flooring system.
- ▶ Install the metal cove strip to the wall to the desired height using contact adhesive, taking care to mask above the cove strip for neatness.
- ▶ Prime the prepared plastered / concrete surfaces with Stonshield 980 Resin A & B at a theoretical coverage of 20 linear metres x 150mm wide per 1 litre kit.
- ▶ Mix the 2,5 litre kits of base and activator of Stonshield 980 Resin for 2 minutes using a JB blender. Add a 5 lt measured bucket (8kg) of Stonshield 981C Aggregate and mix for a further 2 minutes. The yield of this kit is 6 litres. Using a steel trowel, apply the mixed mortar to the wet primed concrete and plastered surfaces to a theoretical spreading rate of 10 linear metres for a 50mm x 100mm x 25mm radius.
- ▶ Form the cove to the desired radius using a suitable coving trowel, allow to cure for 4 to 8 hours at 25°C.
- ▶ Abrade the vertical surface of the cove to remove surface imperfections.
- ▶ Overcoat the coving Stonseal 787 or the specified sealer.

CAUTION: MAY CONTAIN FLAMMABLE SOLVENTS. KEEP AWAY FROM SPARKS AND OPEN FLAMES. IN CONFINED AREAS WORKMEN MUST WEAR FRESH AIRLINE RESPIRATORS. HYPERSENSITIVE PERSONS SHOULD WEAR GLOVES OR USE PROTECTIVE CREAM. ALL ELECTRONIC EQUIPMENT AND INSTALLATIONS SHOULD BE MADE AND GROUNDED IN ACCORDANCE WITH THE NATIONAL ELECTRICAL CODE. IN AREAS WHERE EXPLOSION HAZARDS EXIST, WORKMEN SHOULD BE REQUIRED TO USE NONFERROUS TOOLS AND TO WEAR CONDUCTIVE AND NONSPARKING SHOES